

WE05MFC

Transient Voltage Suppressor

Features

- Solid-state silicon-avalanche technology
- 30 Watts Peak Pulse Power per Line ($t_p=8/20\mu s$)
- Low operating and clamping voltages
- Protects five I/O lines
- Working Voltages: 5 V
- Low Leakage Current

IEC COMPATIBILITY (EN61000-4)

- IEC 61000-4-2 (ESD) $\pm 15kV$ (air), $\pm 8kV$ (contact)
- IEC 61000-4-4 (EFT) 40A (5/50ns)

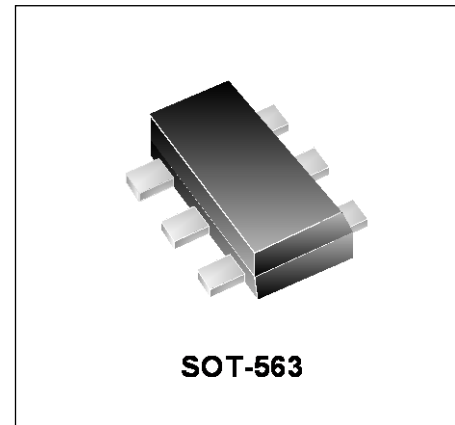

Mechanical Characteristics

- SOT-563 package
- Molding compound flammability rating: UL 94V-0
- Marking: Marking Code
- Packaging: Tape and Reel
- RoHS/WEEE Compliant

Applications

- Cellular Handsets & Accessories
- Personal Digital Assistants (PDAs)
- Notebooks & Handhelds
- Portable Instrumentation
- Digital Cameras
- MP3 Player

Circuit Diagram

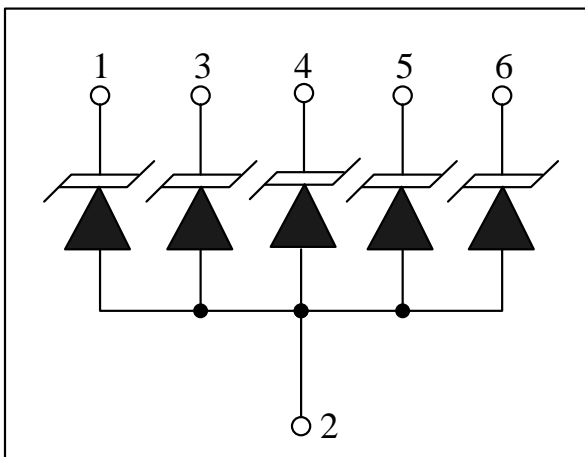

Schematic & PIN Configuration

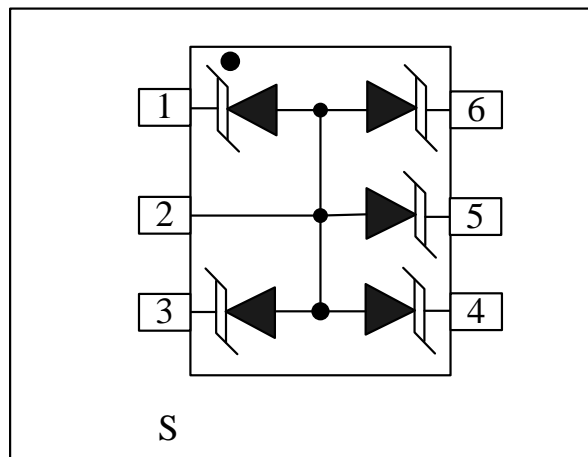

Absolute Maximum Rating			
Rating	Symbol	Value	Units
Peak Pulse Power ($t_p = 8/20\mu s$)	P_{PP}	30	Watts
Peak Forward Voltage ($I_F = 1A, t_p = 8/20\mu s$)	V_{FP}	1.5	V
Operating Temperature	T_J	-55 to + 125	°C
Storage Temperature	T_{STG}	-55 to +150	°C

Electrical Parameters (T=25°C)

Symbol	Parameter
I_{PP}	Maximum Reverse Peak Pulse Current
V_C	Clamping Voltage @ I_{PP}
V_{RWM}	Working Peak Reverse Voltage
I_R	Maximum Reverse Leakage Current @ V_{RWM}
V_{BR}	Breakdown Voltage @ I_T
I_T	Test Current
I_F	Forward Current
V_F	Forward Voltage @ I_F

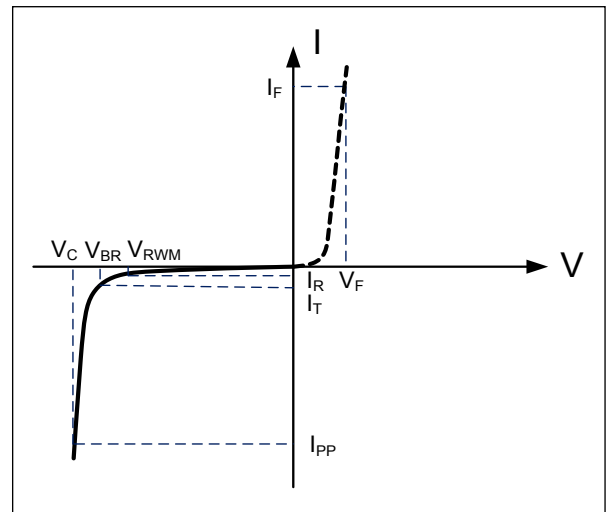

Electrical Characteristics

WE05MFC						
Parameter	Symbol	Conditions	Minimum	Typical	Maximum	Units
Reverse Stand-Off Voltage	V_{RWM}				5.0	V
Reverse Breakdown Voltage	V_{BR}	$I_T = 1mA$	6.0			V
Reverse Leakage Current	I_R	$V_{RWM} = 5V, T = 25°C$			1	μA
Peak Pulse Current	I_{PP}	$t_p = 8/20\mu s$			2.5	A
Clamping Voltage	V_C	$I_{PP} = 2A, t_p = 8/20\mu s$			12	V
Junction Capacitance	C_j	Between I/O pins and Ground $V_R = 0V, f = 1MHz$		6.5		pF

Typical Characteristics

Figure 1: Peak Pulse Power vs. Pulse Time

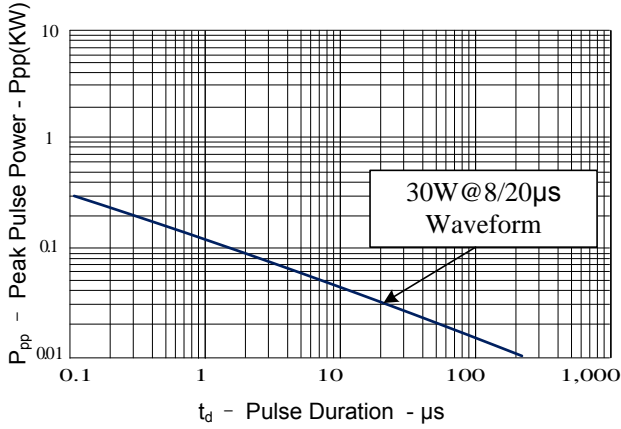

Figure 2: Power Derating Curve

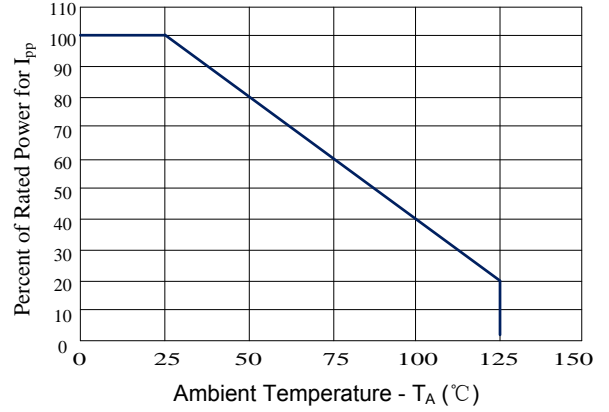

Figure 3: WE05MFC Insertion Loss



Figure 4: Normalized Junction Capacitance vs. Reverse Voltage

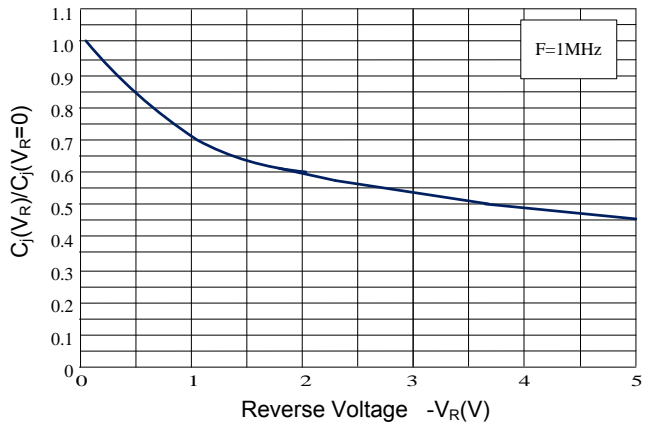
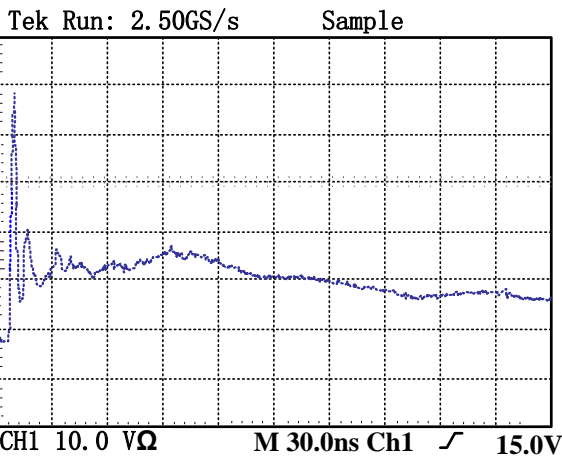

Figure 5: ESD Clamping(8kV Contact per IEC 61000-4-2)



Application Information

The WE05MFC was designed to protect I/O or data lines from the damaging effects of ESD or EFT. This product provides unidirectional and bidirectional protection; the device is connected as follows:

BIDIRECTIONAL COMMON-MODE CONFIGURATION

The WE05MFC provides up to four (4) lines of protection in a common-mode configuration as depicted in Figure 6.

Circuit connectivity is as follows:

- I/O 1 is connected to Pin 3.
- I/O 2 is connected to Pin 1.
- I/O 3 is connected to Pin 6.
- I/O 4 is connected to Pin 4.
- Pin 5 is connected to ground.

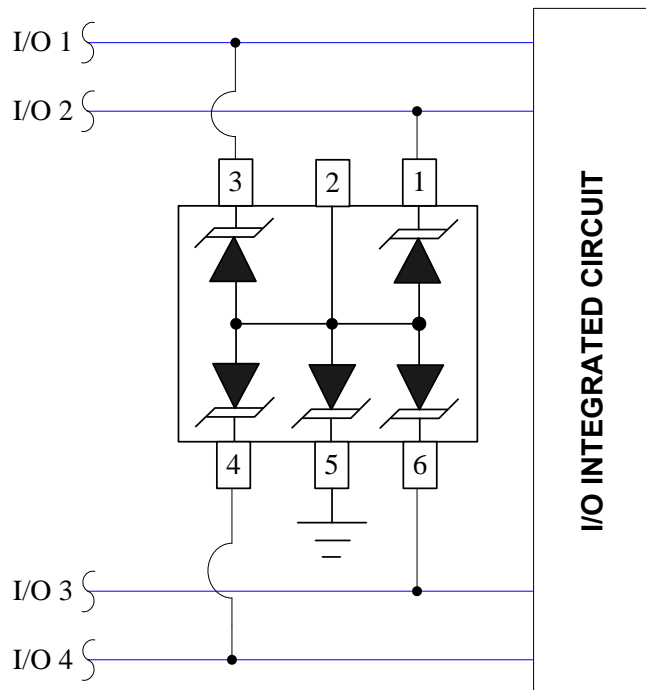

Figure 6 Bidirectional Configuration Common-Mode I/O Port Protections

CIRCUIT BOARD LAYOUT RECOMMENDATIONS

Circuit board layout is critical for Electromagnetic Compatibility (EMC) protection. The following guidelines are recommended:

- The protection device should be placed near the input terminals or connectors, the device will divert the transient current immediately before it can be coupled into the nearby traces.
- The path length between the TVS device and the protected line should be minimized.
- All conductive loops including power and ground loops should be minimized.
- The transient current return path to ground should be kept as short as possible to reduce parasitic inductance.
- Ground planes should be used whenever possible. For multilayer PCBs, use ground vias.

Outline Drawing – SOT-563

PACKAGE OUTLINE

SOT-563

DIMENSIONS				
SYMBOL	INCHES		MILLIMETER	
	MIN	MAX	MIN	MAX
A	0.021	0.024	0.525	0.600
A1	0.000	0.002	0.000	0.050
e	0.018	0.022	0.450	0.550
c	0.004	0.006	0.090	0.160
D	0.059	0.067	1.500	1.700
b	0.007	0.011	0.170	0.270
E1	0.043	0.051	1.100	1.300
E	0.059	0.067	1.500	1.700
L	0.004	0.012	0.100	0.300
θ	7°REF		7°REF	

DIMENSIONS		
DIM	INCHES	MILLIMETERS
Z	0.0752	1.91
G	0.0350	0.89
P	0.020TYP	0.51 TYP
X	0.0118	0.3
Y	0.0201	0.51

Notes

1. Dimensioning and tolerances per ANSI Y14.5M, 1985.
2. Controlling Dimension: Inches
3. Dimensions are exclusive of mold flash and metal burrs.

Marking Codes

Part Number	WE05MFC
Marking Code	E5C